

FAKRA Connector (Die casting PIP)

CDM-K35 / R41-B515

MITSUMI

Features

1. Applicable to automotive antennas for radio frequency signal transmission.
2. Include a die casting body (shell) that can contribute to the robust structure.
3. Selectable variations of mounting requirements. (Right angle / Straight / Standard / Low height)
4. Each coding (mating key) is available.
5. Compatible with Pin-in-Paste.
6. Compliant with RoHS Directive.

CDM-K35



Specifications

Electrical Characteristics

Rated Voltage	60V DC max.
Rated Current	1A DC max.
Characteristic Impedance	50Ω
Insertion Loss	0.15dB max. (0 to 1GHz) 0.25dB max. (1 to 2.5GHz) 0.35dB max. (2.5 to 4GHz)
Return Loss	15.6dB min. (0 to 2GHz) 14.0dB min. (2 to 4GHz)

Mechanical Characteristics

Life (Mating Cycle)	25 times
Total Insertion Force	≤25N
Total Withdrawal Force	≤25N

Material & Finish

Component Parts		Material	Finish
CDM-K35 Die casting PIP	Contact Pin	Copper alloy	Gold plating
	Housing	LCP resin	Natural
	Shell	Zinc alloy	Ni plating
	Cover	Thermoplastic resin	Color: depend each work item

- Any products mentioned in this catalog are subject to any modification in their appearance and others for improvements without prior notification.
- The details listed here are not a guarantee of the individual products at the time of ordering. When using the products, you will be asked to check their specifications.

FAKRA Connector (Die casting PIP)

CDM-K35 / R41-B515

MITSUMI

Dimensions

CDM-K35

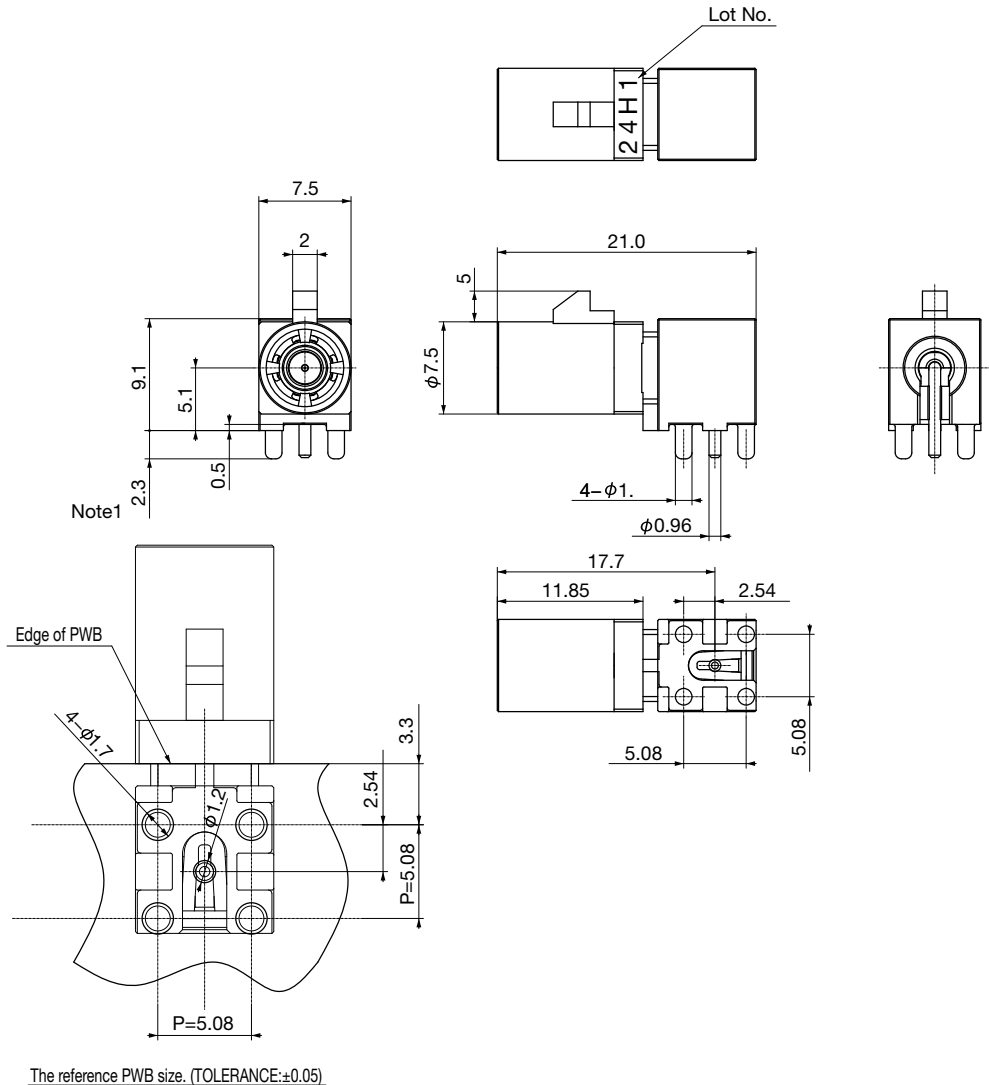

Note1 : Soldering lead 3mm type is also available

Unit: mm

- Any products mentioned in this catalog are subject to any modification in their appearance and others for improvements without prior notification.
- The details listed here are not a guarantee of the individual products at the time of ordering. When using the products, you will be asked to check their specifications.