

For Home Appliances
No Plate No Cover

Characteristic

- Motor Type
3 Phase DC Brushless Motor
- Direction of Rotation
CW and CCW
- Control-Driver circuit built-in.
- Compact, Light Weight and High Output
- High Efficiency
- Low Noise
- Overcurrent and Locked Rotor Protection



- Φ 61
- DC Brushless motor outer rotor type

Major Characteristic Parameters

| Item | Min. | Nom. | Max. | Units |
|-------------------------|------|------|------|-------------------|
| Operating Voltage | 21.6 | 24 | 26.4 | VDC |
| Operating Speed | 300 | 1000 | 3000 | min ⁻¹ |
| Continuous Rating Power | | 25 | | W |
| Operating Temperature | 0 | | 50 | °C |
| Operating Humidity | 15 | | 90 | %RH |

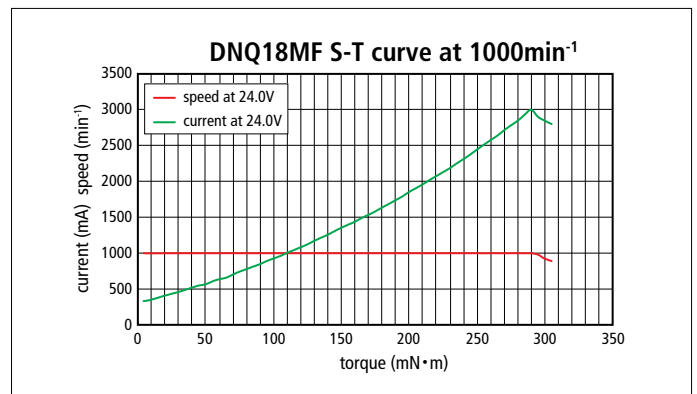

Outside Dimension (Reference)

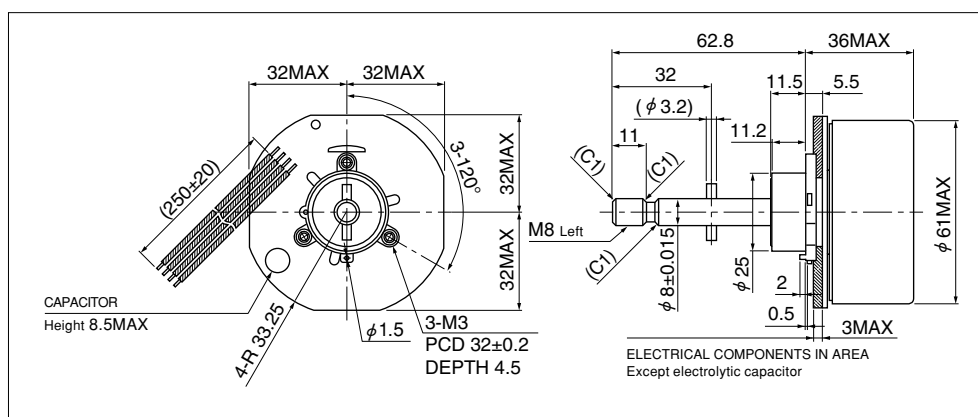

Please contact our sales for detail specification & order lot QTY. (All custom product by customer's requirement)