

Characteristic

- Motor Type
 - 3 Phase DC Brushless Motor
- Direction of Rotation
 - CW and CCW
- Control-Driver circuit built-in.
- Compact, Light Weight and High Output
- High Efficiency
- Low Noise
- Overcurrent and Locked Rotor Protection
- The gear machined output, shaft type is available as an option.



- $\Phi 49 \times L25$
- DC Brushless motor outer rotor type

Major Characteristic Parameters

Item	Min.	Nom.	Max.	Units
Operating Voltage	21.6	24	26.4	VDC
Operating Speed	600		3000	min ⁻¹
Continuous Rating Power			11	W
Rotor Inertia (Reference Value)		159		g·cm ²
Operating Temperature	0	20	50	°C
Operating Humidity	15		90	%RH
Motor Weight			170	g

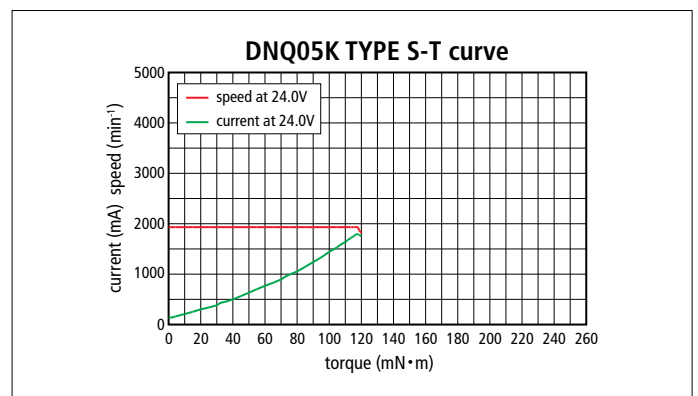

Outside Dimension (Reference)

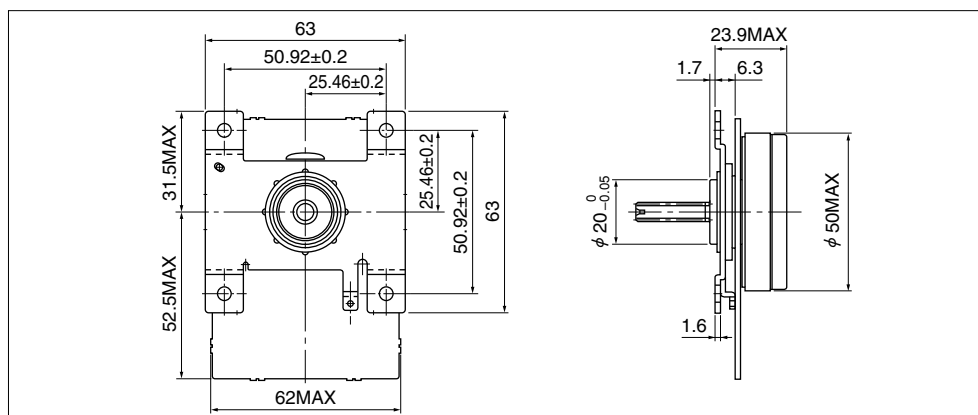

Please contact our sales for detail specification & order lot QTY. (All custom product by customer's requirement)