

# BLDC 40P30F

11P2.071D

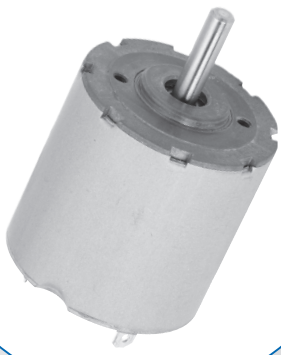

Rated Voltage	No Load Speed	Rated Speed	Cont. Power	Rated Torque	Current at rated Speed	Efficiency at Duty Point
[ V ]	[ rpm ]	[ rpm ]	[ W ]	[ mNm ]	[ A ]	[ % ]
12	18.545	12.655	241	182	26,3	82

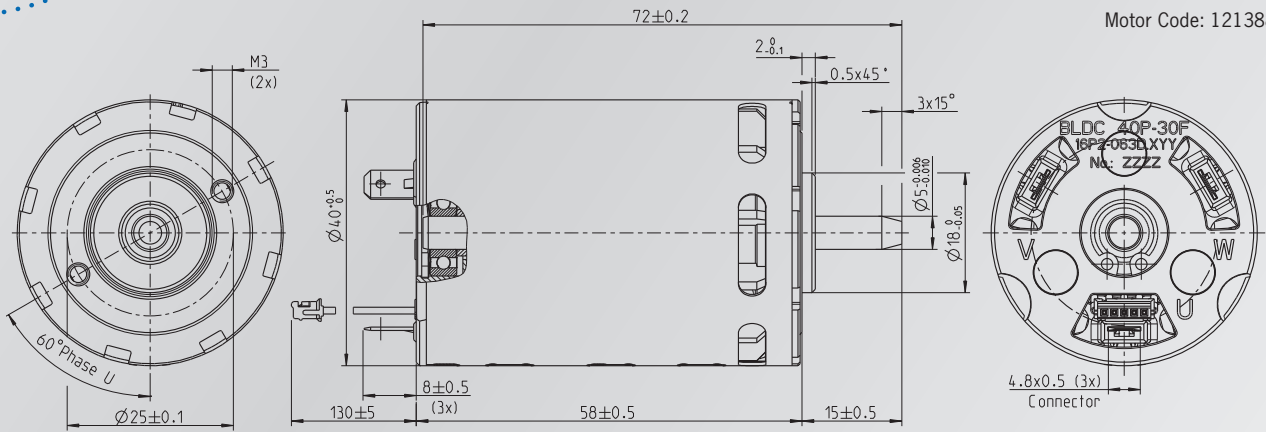

## General informations

- **Class of protection:** IP20
- **Mounting position:** free
- **Duty cycle:** up to 100 %
- **Bearing system:** Ball Bearings
- **Torque Constant:** 5,8 mNm/A
- **Weight:** 0,285 kg
- **Rotor Inertia:** 40 gcm<sup>2</sup>
- **Oper. Temp. Range:** -20 °C to +45 °C
- **Max. Temp. Rise:** 70 K
- **Direction of Rotation:** CW / CCW
- **Class of Insulation:** H
- **Shaft Material:** Steel, not hardened
- **Number of Poles:** 8

## Options

- **Integrated Drive Electro.:** Yes
- **Planetary Gearbox:** Yes
- **Sensorless Operation:** Yes
- **Shaft hardened (Surface):** Yes

## Features

- High power-to-volume ratio
- High efficiency at duty point
- Extremely reliable

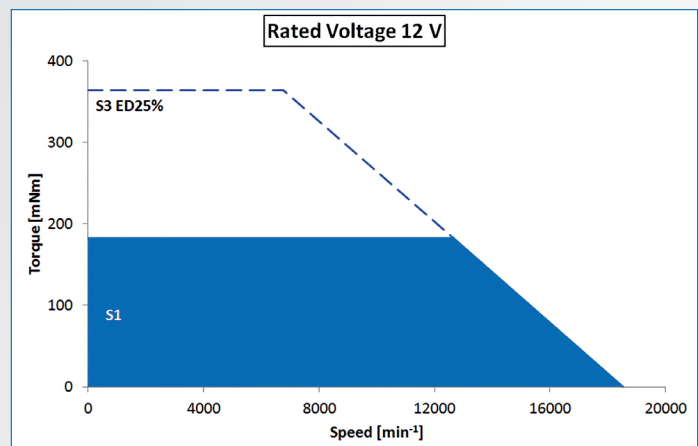

NMB Technologies Corporation  
 A MinebeaMitsumi Group Company  
 39830 Grand River Avenue  
 Novi, MI 48375  
 Tel: 248-919-2250  
 eMail: info@nmbtc.com  
 nmbtc.com